



## SERIES: **FIRG**

**INTERCHANGE:** ISO 16028 and NFPA T3.20.15 (HTMA)

### MAIN APPLICATIONS

- Mobile construction equipment
- Hydraulic tools
- Vehicles
- Industrial equipment

“FIRG” is the “**original one**” of the flat face coupling series. Created in 1983, the “FIRG” series has represented a great innovation in the quick couplings field. Used in a wide range of hydraulic applications, the “FIRG” series over time has become the leading series for the realization of ISO 16028 interchangeability. Based on the durable performance and many benefits the series offers, “FIRG” series is most frequently used and approved in the world-wide hydraulic equipment manufacturer’s market. It finds approval in all the applications where fluid loss and contamination of the hydraulic circuit needs to be eliminated.



**Stucchi**<sup>®</sup>

A CONSTANT FLOW OF SOLUTIONS

## TECHNICAL FEATURES AND OPTIONS

- Interchangeability: ISO 16028 (from size 6.3 to 25) HTMA (size 10)
- Surface treatment: CrIII zinc plated
- Mechanical connection: Locking balls
- Connection system: Pushing one half towards the other
- Disconnection system: Pulling back the sleeve of female
- Connection with residual pressure: Not allowed
- Disconnection with residual pressure: Not allowed
- Threads available: BSP, NPT, SAE
- Construction material: Carbon steel
- Valve system: Flat face
- External springs: AISI 302
- Internal springs: C72 steel
- Balls: Hard steel 100 C6
- Seals: standard in NBR (Nitrile)
- Seals on request: VITON or others
- Anti-extrusion rings: PTFE

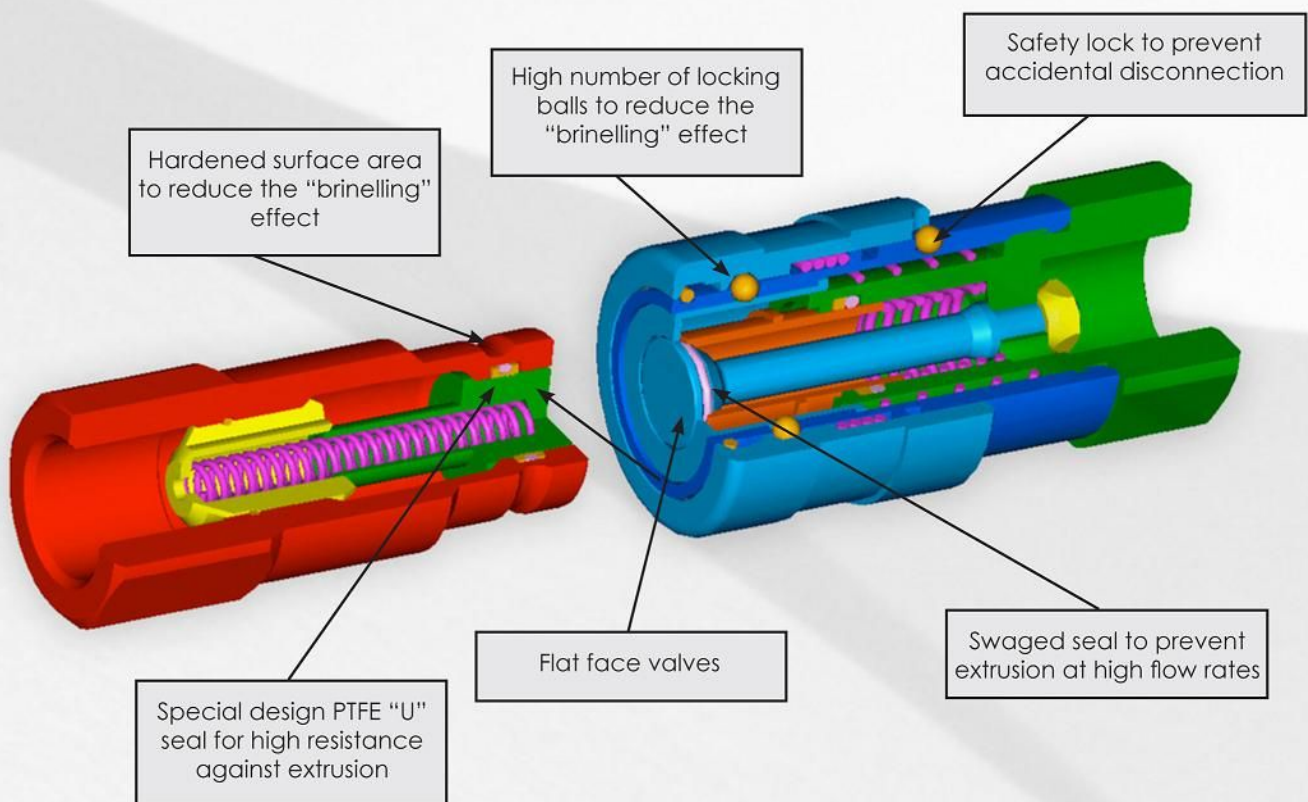

## BENEFITS

- Flat face is easy to clean, helping to reduce the inclusion of contamination to the hydraulic circuit.
- Minimal fluid loss during connection / disconnection, reducing fluid loss to the environment.
- Minimal air inclusion during connection / disconnection, enhancing correct function of the circuit.
- Linear flow reduces internal turbulence and pressure drop, maintaining circuit efficiency in the entire system.
- Good resistance at impulse pressures.
- Compact slim design.
- Safe and simple to use.



## HOW TO USE

- Before to couple clean the flat mating surface of quick coupling to avoid the inclusion of dirty in the circuit.
- To couple push the male half towards the female half or vice versa.
- After connection turn the external sleeve to engage lock function, to prevent accidental disconnection.
- To uncouple turn the external sleeve until the sleeve lock groove corresponds with the safety lock ball and pull back the sleeve.

## WARNING!

- Do not use the female coupling disconnected with impulse pressure.
- Do not couple-uncouple with flow and/or pressure in the circuit.
- Do not couple-uncouple when the temperature inside of the circuit is higher than 80 °C (176 °F).
- When the couplings are disconnected, it is suggested to use the protection caps.

## PERFORMANCE

Description	Size	ISO Size	Rated flow		Max. flow suggested		Connect force		Disconnect force		Spillage*
			l/min	GPM	l/min	GPM	N	lbf	N	lbf	
FIRG14	1/4	6,3	12	3,18	24	6,36	140	31,50	40	9,00	0,006
FIRG38-12	3/8	10,0	23	6,10	46	12,19	150	33,75	40	9,00	0,012
FIRG12A-34	1/2	12,5	45	11,93	90	23,85	160	36,00	60	13,50	0,020
FIRG34B	5/8	16,0	74	19,61	148	39,22	180	40,50	55	12,38	0,026
FIRG34A	3/4	19,0	100	26,50	170	45,05	270	60,75	90	20,25	0,032
FIRG100	3/4	19,0	100	26,50	200	53,00	240	54,00	65	14,63	0,032
FIRG114	1	25,0	189	50,09	378	100,17	310	69,75	100	22,50	0,035
FIRG112	1-1/2	-	288	76,32	750	198,75	390	87,75	90	20,25	0,050
FIRG200	2	-	379	100,44	1000	265,00	470	105,75	100	22,50	0,100

Description	Max. operating pressure						Burst pressure					
	Coupled		Male		Female		Coupled		Male		Female	
	MPa	psi	MPa	psi	MPa	psi	MPa	psi	MPa	psi	MPa	psi
FIRG14	30	4350	42	6090	12	1740	120	17400	126	18270	48	6960
FIRG38-12	30	4350	30	4350	12	1740	120	17400	120	17400	48	6960
FIRG12A-34	25	3625	25	3625	10	1450	100	14500	100	14500	40	5800
FIRG34B	25	3625	22	3190	10	1450	100	14500	88	12760	40	5800
FIRG34A	33	4785	33	4785	33	4785	100	14500	100	14500	100	14500
FIRG100	25	3625	20	2900	10	1450	100	14500	80	11600	40	5800
FIRG114	25	3625	20	2900	10	1450	100	14500	80	11600	40	5800
FIRG112	20	2900	27	3915	8	1160	80	11600	80	11600	32	4640
FIRG200	20	2900	16	2320	8	1160	80	11600	64	9280	32	4640

\* Spillage is an indicative value of the fluid loss per couple-uncouple cycle.

### • Temperature range:

- Standard seals NBR (Nitrile): from -20 °C to +100 °C ( from -4 °F to +212 °F).
- VITON seals: from -15°C to +180°C ( from +5 °F to +356 °F).

### • Tests:

- The couplings have been tested at impulse with max. operating pressure for 100.000 impulses in according with ISO 7241-2.

**PRESSURE DROP**

TESTS ESEGUITI IN CONFORMITA' A ISO 7241-2  
 TESTS IN ACCORDANCE WITH ISO 7241-2

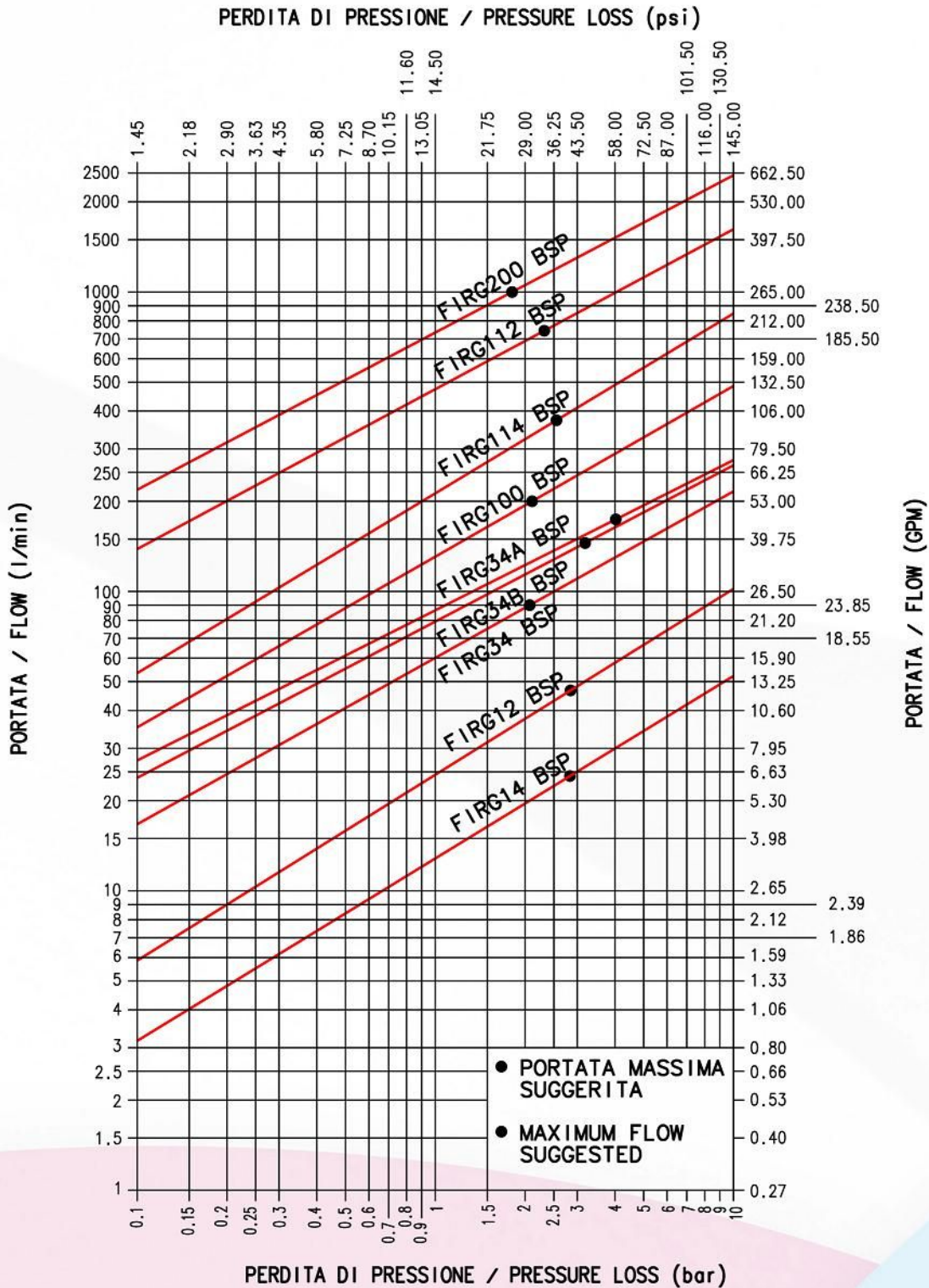

FLUIDO: OLIO ISO VG32  
 TEMPERATURA: 40°C  
 VISCOSITA': 28.8-35.2 mm<sup>2</sup>/s

FLUID: OIL ISO VG32  
 TEMPERATURE: 40°C  
 VISCOSITY: 28.8-35.2 mm<sup>2</sup>/s



## OVERALL DIMENSIONS

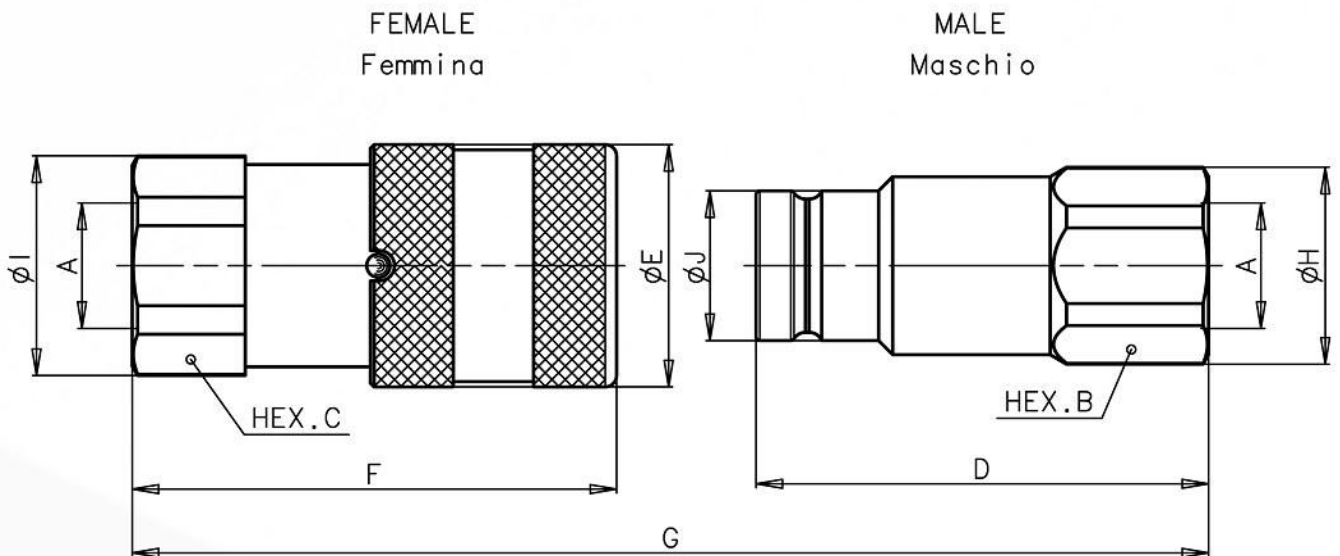

## FEMALE BSP THREAD (DIN 3852)

Description	A	Unit	B	C	D	E	F	G	H	I	J	Unit	Weight	
													Male	Female
FIRG14 BSP	1/4	mm Inch	22 0,87	22 0,87	47,9 1,89	28 1,10	48,1 1,89	85,2 3,35	23,8 0,94	23,8 0,94	16,1 0,63	Kg lb	0,086 0,19	0,140 0,31
FIRG38 BSP	3/8	mm Inch	24 0,94	27 1,06	60 2,36	32 1,26	64,2 2,53	108,7 4,28	26 1,02	29 1,14	19,7 0,78	Kg lb	0,121 0,27	0,235 0,52
FIRG12 BSP	1/2	mm Inch	27 1,06	27 1,06	62,5 2,46	32 1,26	69,2 2,72	116,2 4,57	29 1,14	29 1,14	19,7 0,78	Kg lb	0,128 0,28	0,237 0,52
FIRG12A BSP	1/2	mm Inch	32 1,26	32 1,26	68 2,68	38 1,50	73,8 2,91	124,5 4,90	33,8 1,33	33,8 1,33	24,5 0,96	Kg lb	0,233 0,51	0,375 0,83
FIRG34 BSP	3/4	mm Inch	36 1,42	36 1,42	70,5 2,78	38 1,50	80,8 3,18	134 5,28	38,5 1,52	38,5 1,52	24,5 0,96	Kg lb	0,227 0,50	0,413 0,91
FIRG34B BSP	3/4	mm Inch	36 1,42	36 1,42	70,5 2,78	42 1,65	78,5 3,09	131,4 5,17	38,5 1,52	38,5 1,52	27 1,06	Kg lb	0,268 0,59	0,479 1,06
FIRG34A BSP	3/4	mm Inch	41 1,61	41 1,61	82,3 3,24	48 1,89	88,7 3,49	149 5,87	44,8 1,76	44,8 1,76	30 1,18	Kg lb	0,445 0,98	0,750 1,65
FIRG100 BSP	1	mm Inch	45 1,77	45 1,77	82,3 3,24	48 1,89	93,2 3,67	153,5 6,04	47,8 1,88	47,8 1,88	30 1,18	Kg lb	0,394 0,87	0,767 1,69
FIRG114 BSP	1-1/4	mm Inch	55 2,17	55 2,17	89,8 3,54	55 2,17	106 4,17	172,8 6,80	59,8 2,35	59,8 2,35	36 1,42	Kg lb	0,641 1,41	1,215 2,68
FIRG112 BSP	1-1/2	mm Inch	65 2,56	65 2,56	111,1 4,37	80 3,15	132,4 5,21	214,9 8,46	69,8 2,75	72 2,83	57 2,24	Kg lb	1,665 3,67	2,820 6,22
FIRG200 BSP	2	mm Inch	75 2,95	80 3,15	123,8 4,87	100 3,94	156,6 6,17	241,5 9,51	83,5 3,29	88,5 3,48	73 2,87	Kg lb	2,259 4,98	5,100 11,24

## OVERALL DIMENSIONS

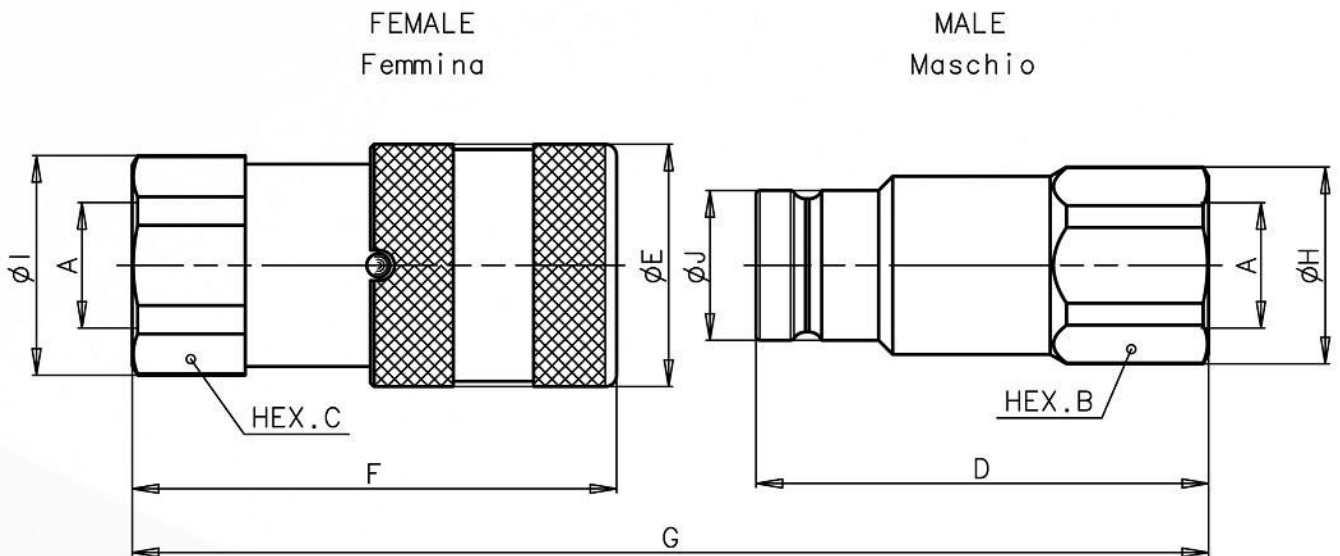

## FEMALE NPT THREAD (ANSI B.1.20.3)

Description	A	Unit	B	C	D	E	F	G	H	I	J	Unit	Weight	
													Male	Female
FIRG14 NPT	1/4	mm Inch	22 0,87	22 0,87	47,9 1,89	28 1,10	48,1 1,89	85,2 3,35	23,8 0,94	23,8 0,94	16,1 0,63	Kg lb	0,088 0,19	0,140 0,31
FIRG38 NPT	3/8	mm Inch	24 0,94	27 1,06	60 2,36	32 1,26	64,2 2,53	108,7 4,28	26 1,02	29 1,14	19,7 0,78	Kg lb	0,123 0,27	0,237 0,52
FIRG12 NPT	1/2	mm Inch	27 1,06	27 1,06	62,5 2,46	32 1,26	69,2 2,72	116,2 4,57	29 1,14	29 1,14	19,7 0,78	Kg lb	0,130 0,29	0,240 0,53
FIRG12A NPT	1/2	mm Inch	32 1,26	32 1,26	68 2,68	38 1,50	73,8 2,91	124,5 4,90	33,8 1,33	33,8 1,33	24,5 0,96	Kg lb	0,236 0,52	0,378 0,83
FIRG34 NPT	3/4	mm Inch	36 1,42	36 1,42	70,5 2,78	38 1,50	80,8 3,18	134 5,28	38,5 1,52	38,5 1,52	24,5 0,96	Kg lb	0,234 0,52	0,420 0,93
FIRG34B NPT	3/4	mm Inch	36 1,42	36 1,42	70,5 2,78	42 1,65	78,5 3,09	131,4 5,17	38,5 1,52	38,5 1,52	27 1,06	Kg lb	0,273 0,60	0,490 1,08
FIRG34A NPT	3/4	mm Inch	41 1,61	41 1,61	82,3 3,24	48 1,89	88,7 3,49	149 5,87	44,8 1,76	44,8 1,76	30 1,18	Kg lb	0,450 0,99	0,755 1,66
FIRG100 NPT	1	mm Inch	45 1,77	45 1,77	82,3 3,24	48 1,89	93,2 3,67	153,5 6,04	47,8 1,88	47,8 1,88	30 1,18	Kg lb	0,405 0,89	0,781 1,72
FIRG114 NPT	1-1/4	mm Inch	55 2,17	55 2,17	89,8 3,54	55 2,17	106 4,17	172,8 6,80	59,8 2,35	59,8 2,35	36 1,42	Kg lb	0,662 1,46	1,215 2,68
FIRG112 NPT	1-1/2	mm Inch	65 2,56	65 2,56	111,1 4,37	80 3,15	132,4 5,21	214,9 8,46	69,8 2,75	72 2,83	57 2,24	Kg lb	1,670 3,68	2,848 6,28
FIRG200 NPT	2	mm Inch	75 2,95	80 3,15	123,8 4,87	100 3,94	156,6 6,17	241,5 9,51	83,5 3,29	88,5 3,48	73 2,87	Kg lb	2,259 4,98	5,100 11,24



## OVERALL DIMENSIONS

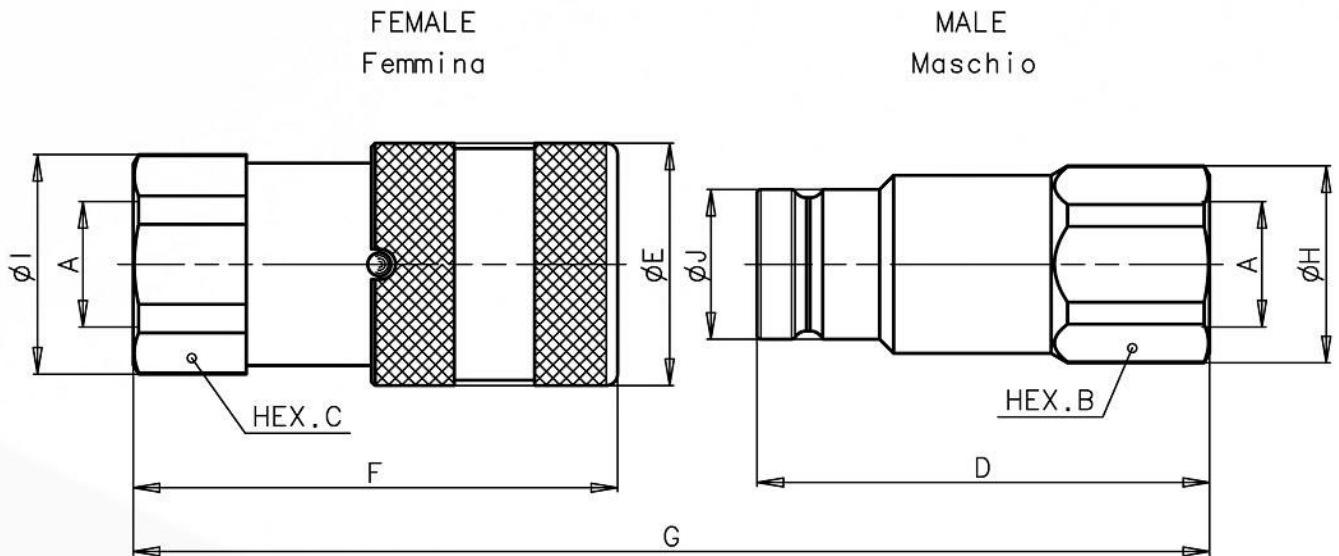

## FEMALE SAE THREAD (SAE J1926-1)

Description	A	Unit	B	C	D	E	F	G	H	I	J	Unit	Weight	
													Male	Female
FIRG14 3/8 SAE	9/16- 18UNF	mm Inch	22 0,87	22 0,87	50,9 2,00	28 1,10	53,1 2,09	93,2 3,67	23,8 0,94	23,8 0,94	16,1 0,63	Kg lb	0,091 0,20	0,148 0,33
FIRG38 1/2 SAE	3/4-16 UNF	mm Inch	27 1,06	27 1,06	62,5 2,46	32 1,26	69,2 2,72	116,2 4,57	29 1,14	29 1,14	19,7 0,78	Kg lb	0,140 0,31	0,244 0,54
FIRG12 5/8 SAE	7/8-14 UNF	mm Inch	30 1,18	30 1,18	64 2,52	32 1,26	71,2 2,80	119,7 4,71	32 1,26	32 1,26	19,7 0,78	Kg lb	0,146 0,32	0,258 0,57
FIRG12A 5/8 SAE	7/8-14 UNF	mm Inch	32 1,26	32 1,26	70 2,76	38 1,50	76,3 3,00	129 5,08	33,8 1,33	33,8 1,33	24,5 0,96	Kg lb	0,231 0,51	0,378 0,83
FIRG34 SAE	1-1/16- 12 UN	mm Inch	36 1,42	36 1,42	72 2,83	38 1,50	83,3 3,28	138 5,43	38,5 1,52	38,5 1,52	24,5 0,96	Kg lb	0,231 0,51	0,421 0,93
FIRG34B SAE	1-1/16- 12 UN	mm Inch	36 1,42	36 1,42	72 2,83	42 1,65	83,5 3,29	137,9 5,43	38,5 1,52	38,5 1,52	27 1,06	Kg lb	0,267 0,59	0,497 1,10
FIRG34A SAE	1-1/16- 12 UN	mm Inch	41 1,61	41 1,61	82,3 3,24	48 1,89	88,7 3,49	149 5,87	44,8 1,76	44,8 1,76	30 1,18	Kg lb	0,440 0,97	0,745 1,64
FIRG100 SAE	1-5/16- 12 UN	mm Inch	45 1,77	45 1,77	82,3 3,24	48 1,89	93,2 3,67	153,5 6,04	47,8 1,88	47,8 1,88	30 1,18	Kg lb	0,394 0,87	0,767 1,69
FIRG114 SAE	1-5/8- 12 UN	mm Inch	55 2,17	55 2,17	89,8 3,54	55 2,17	106 4,17	172,8 6,80	59,8 2,35	59,8 2,35	36 1,42	Kg lb	0,641 1,41	1,215 2,68
FIRG112 SAE	1-7/8- 12 UN	mm Inch	65 2,56	65 2,56	111,1 4,37	80 3,15	132,4 5,21	214,9 8,46	69,8 2,75	72 2,83	57 2,24	Kg lb	1,655 3,65	2,820 6,22
FIRG200 SAE	2-1/2- 12 UN	mm Inch	75 2,95	80 3,15	123,8 4,87	100 3,94	156,6 6,17	241,5 9,51	83,5 3,29	88,5 3,48	73 2,87	Kg lb	2,259 4,98	5,100 11,24